



USER MANUAL

GPStoCAN

Document version: 3.2

Firmware version: 2.0 or later

Published on: 09 December 2025



Contents

1. Device description.....	3
2. Specification.....	3
3. Installation.....	5
4. PC connection.....	8
5. Light Client description.....	8
6. CAN Stream.....	12
7. Document history.....	15

1. Device description

GPStoCAN V2 is a device designed to provide position information over the CAN bus. This module can use up to four concurrent navigation systems (GPS, GLONASS, BeiDou, Galileo) to provide position updates at a rate of 25 Hz. The position data can be used to measure lap times, estimate current lap times, create track maps, and analyze vehicle logs with respect to track position.

GPStoCAN V2 is available in two variants: **Basic (DT)** and **Autosport (AS)**. The key differences between the two versions are the type of connector and the CAN bus termination.

2. Specification

Specification		
General		
Operating supply voltage	6-22 V, immunity to transients according to ISO 7637	
Reverse polarity protection	Yes, internal up to 16 V	
Temperature range	-40 to +85 °C	
Enclosure	IP65, bespoke CNC machined aluminum	
Size and weight (DT version)	66×53×44 mm, 92 g	
Size and weight (AS version)	66×49×44 mm, 74 g	
Connector (DT version)	Plug: Deutsch DT06-4S	Socket: Deutsch DT15-4P
Connector (AS version)	Plug: Deutsch ASX602-06SN	Socket: Deutsch ASX202-06PN
CAN bus bitrate	1 Mbps (default), 500 kbps, 250 kbps, 125 kbps	
PC communication	Using USB to CAN interface (Ecumaster USBtoCAN, Peak, Kvaser)	
LED colors	Red – no position fix Green – position fix ready	
CAN termination	None - in the DT version Configurable - in the AS version	
Navigation		
Supported systems	GPS, GLONASS, BeiDou, Galileo	
Supported antennas	Active	
Position update frequency	25 Hz	

IMU update frequency	100 Hz
Velocity accuracy	0.05 m/s
Velocity maximum	500 m/s
Velocity resolution	0.01 m/s
Velocity latency	< 20 ms
Position accuracy	2 m
Height accuracy	2.5 m
Heading accuracy	0.3°
Heading resolution	0.01°
Acquisition	Cold start: 24 sec Hot start: 2 sec

All dimensions in mm

X – front

Y – right

Z – down

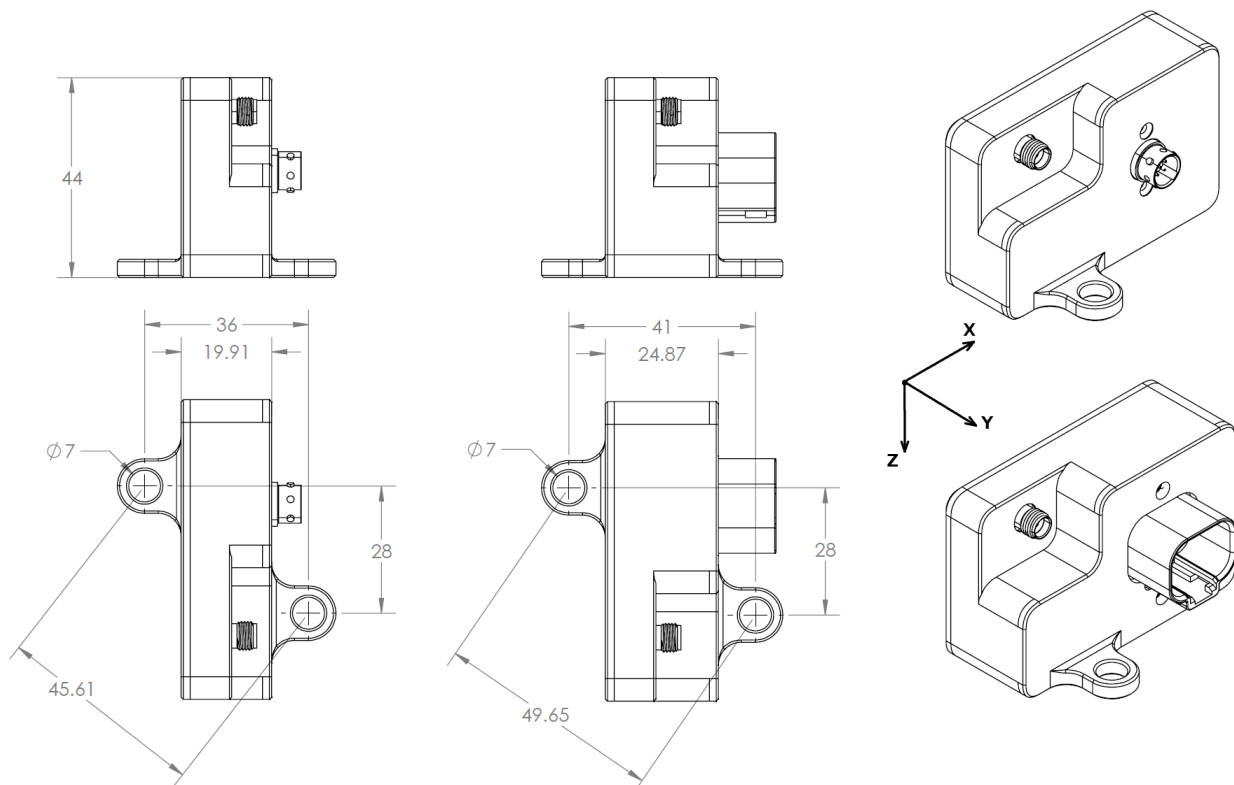

3. Installation

Pinout

DEUTSCH DT	
Pin	Description
1	Ground
2	CAN High
3	CAN Low
4	+12V (switched power supply)

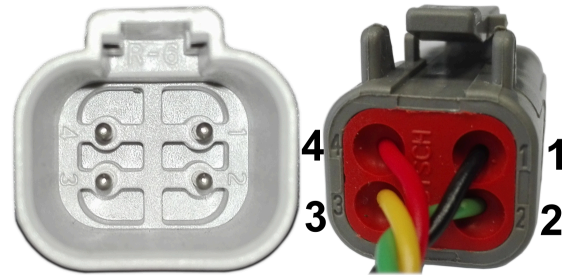

DEUTSCH AS	
Pin	Description
1	+12V (switched power supply)
2	CAN High
3	Short these pins together to add CAN termination resistor
4	
5	CAN Low
6	Ground

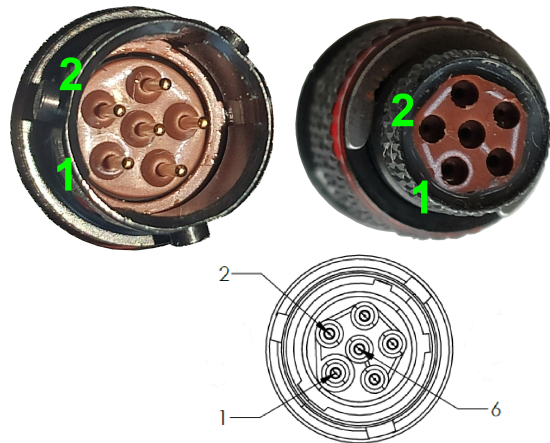

In the **DT** version, there is no internal termination resistor. In the **AS** version, a termination resistor is included, which can be activated by shorting Pin 3 and Pin 4.

Wiring diagrams

DT version

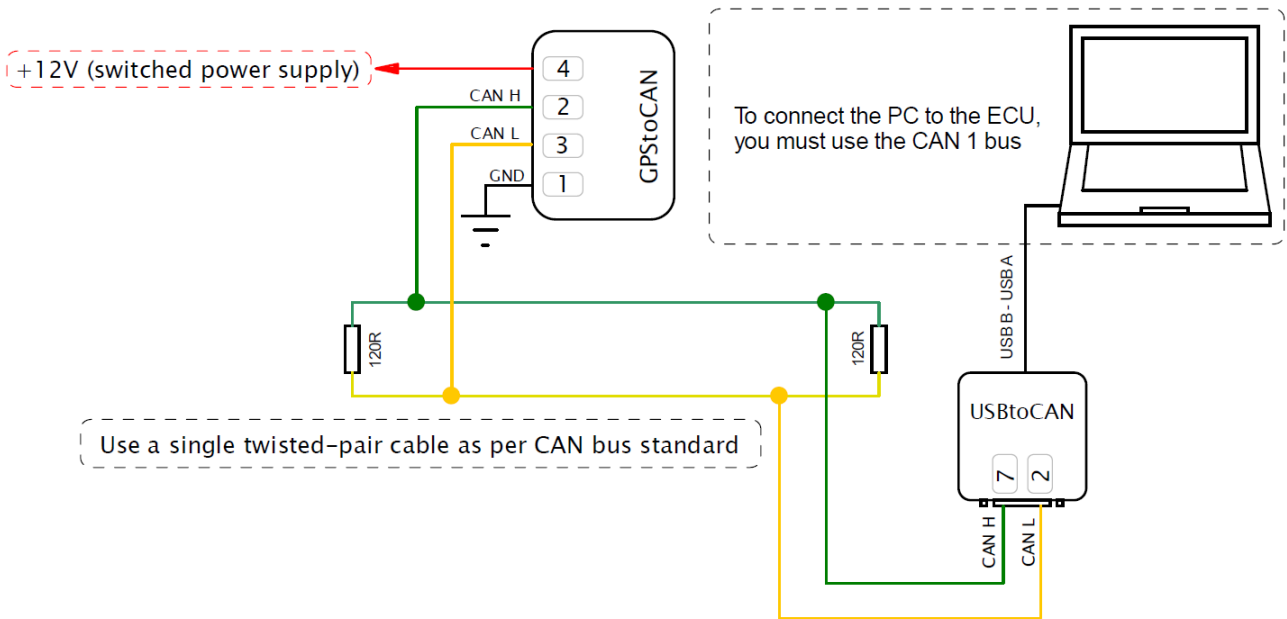

AS version

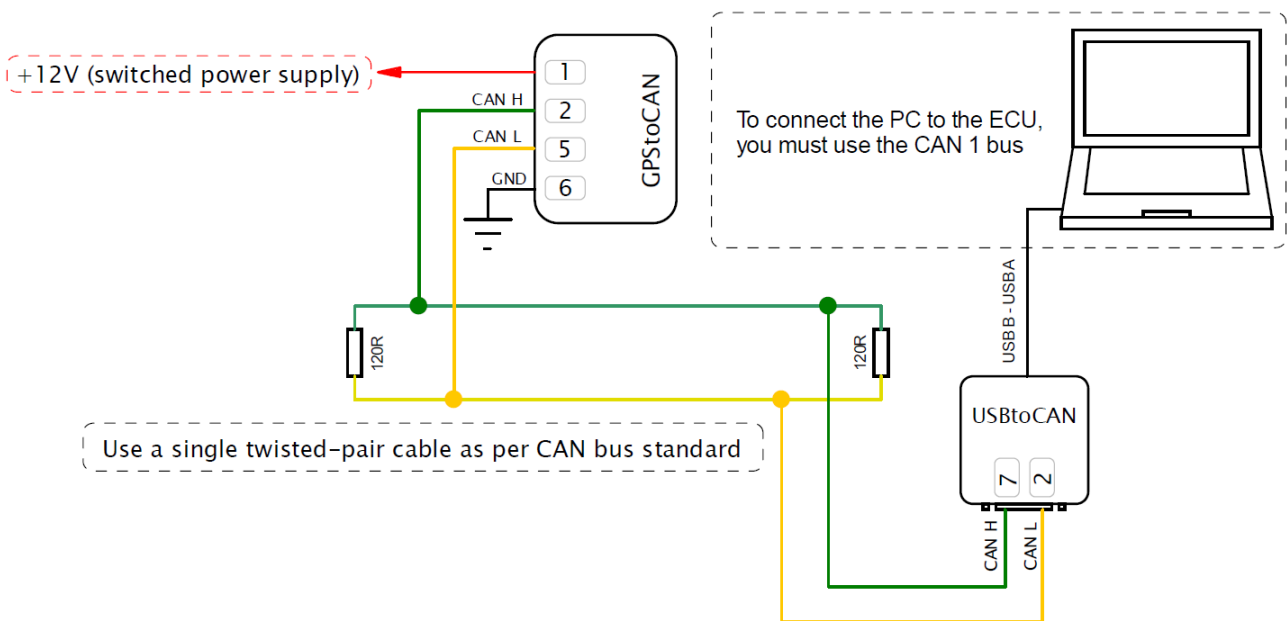

Mounting

The ideal mounting position is in the middle of the vehicle, attached to the vehicle frame using the included rubber dampers, and oriented as shown below. Acceleration in the directions shown gives positive values:

X – front

Y – right

Z – down

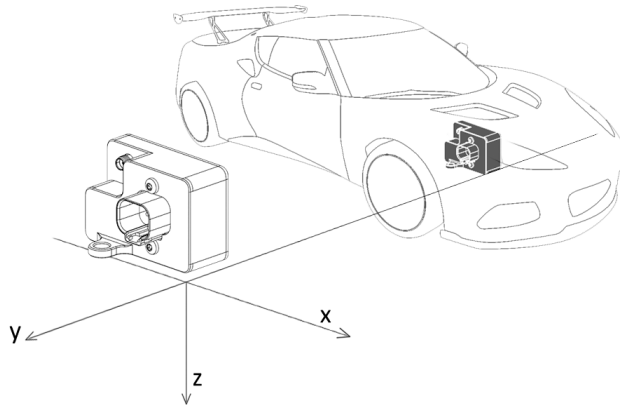

The GPStoCAN V2 module must be mounted with the rubber dampers in a vertical orientation (Z-axis pointing down). Mounting the module to a vertical plane with the dampers oriented horizontally can cause issues with the IMU, as bumps in the road could significantly move the module up and down relative to the vehicle.

Antenna connection

The GPStoCAN V2 module is designed to work with active antennas. The ideal antenna placement is on a large metal surface (roof, hood, trunk) with a clear view of the sky. The most common way to mount the antenna is on the roof using the magnetic base.

The antenna wire should be routed away from any harnesses carrying high currents or voltages (such as the engine harness). Rapidly changing currents or voltages can generate noise in the antenna wire and interfere with the GNSS signal.



Note:

When installing the antenna connector, do not overtighten, as you may damage the threads.

The recommended tightening torque is **4 Nm**. Exceeding this value may damage the antenna connector or the GPStoCAN module.

4. PC connection

Communication with the PC software is done via CAN bus, which requires a special interface to convert CAN bus communication to USB 2.0. This interface is an independent device and must be purchased separately.

Supported interfaces:

- Ecumaster USBtoCAN (driver and manual: <https://www.ecumaster.com/products/usb-to-can/>)
- PEAK-System
- Kvaser

5. Light Client description

Ecumaster Light Client is the configuration software for many Ecumaster products and also serves as a tool for CAN bus monitoring.

Light Client can be used to check available devices on the CAN bus, display channel values, change CAN bus bitrate, and modify device specific properties. CAN bus monitoring is made possible through a list of frames grouped by ID, the ability to save traffic trace files, and the option to send custom messages on the CAN bus.

The software and manual can be downloaded from: <https://www.ecumaster.com/products/light-client/>

Properties

Device properties can be changed using the Ecumaster Light Client software and the connection interface. Each property is described below:

Ecumaster output:

Parameter	Description
Enable	Enables Ecumaster CAN frames output
Output CAN ID	The base frame ID for Ecumaster output

Format M output:

Parameter	Description
Enable	Enables format M CAN frames output
Output CAN ID	The base frame ID for format M output

High rate IMU output:

Parameter	Description
Enable	Enables high rate IMU CAN frames output
Output CAN ID	The base frame ID for high rate IMU output

Navigation config:

Parameter	Description
Navigation systems	Selected navigation systems to use in positioning

Static hold config:

Parameter	Description
Enable	Enables static hold, this option holds position constant and speed equal to 0 until distance or speed threshold is exceeded
Distance threshold	The threshold in meters for static hold to deactivate
Speed threshold	The threshold in kilometers per hour for static hold to deactivate

Channels

Channels represent different data values sent over the CAN bus. These channels are transmitted as raw values, meaning that obtaining a value with the correct unit requires some calculations.

$$Value[unit] = \frac{Value[raw] * Multiplier}{Divider} + Offset$$

The tables in the [CAN Stream \(on page 12\)](#) section describe how each channel is positioned within CAN frames and how to obtain the correct values. All values are in Big Endian format.

Ecumaster format output:

Channel	Description
Latitude	Latitude position in degrees
Longitude	Longitude position in degrees
Speed	Ground speed in kilometers per hour
Height	Height above mean sea level in meters
Satellites number	Number of currently visible satellites
GPS frame index	Increments cyclically from 0 to 15 for each position frame
Empty frame index	Increments cyclically from 0 to 15 for each empty frame
GPS status	Position fix status: <ul style="list-style-type: none"> • 1 - "NoFix" - no position fix acquired • 3 - "GPS-2D" - position is fixed in 2D space using GNSS satellites • 4 - "GPS-3D" - position is fixed in 3D space using GNSS satellites
Heading motion	Direction of vehicle motion in degrees
Heading vehicle	Direction in which vehicle front is heading in degrees
X, Y, Z angle rate	Angular velocity around longitudinal, lateral and vertical axis(referenced to the vehicle frame)
X, Y, Z acceleration	Longitudinal, lateral and vertical acceleration (referenced to the vehicle frame)
UTC year, month, day	UTC date from navigation satellites
UTC hour, minute, second, millisecond	UTC time from navigation satellites

Format M output:

Channel	Description
Latitude (M)	Latitude position in degrees
Longitude (M)	Longitude position in degrees
Time (M)	Time in HHMMSS.sss format
Speed (M)	Ground speed in kilometers per hour
Altitude (M)	Height above mean sea level in meters
Date (M)	Date in DDMMYY format

Channel	Description
Valid (M)	Position data valid: <ul style="list-style-type: none"> • -1 - "Warning" - position data may be invalid • 0 - "Unknown" - position data is unknown • 1 - "Valid" - position data is valid
True course (M)	Direction of vehicle motion in degrees
Satellites (M)	Number of currently visible satellites
FAA mode (M)	Duplicate of 'Fix quality 2' field, see below
Fix quality (M)	Fix quality status: <ul style="list-style-type: none"> • -1 - "Unknown" - unknown fix quality • 0 - "Invalid" - not enough satellites, invalid fix quality • 1 - "GPS" - standard GPS signal position fix

High rate IMU output:

Channel	Description
HR X, Y, Z ang rate	High rate angular velocity around longitudinal, lateral and vertical axis
HR X, Y, Z accel	High rate longitudinal, lateral and vertical acceleration

6. CAN Stream

The default CAN bus bitrate of the device is **1 Mbps**. The format used is **big-endian**.

Ecumaster format output:

Byte	Bit	Channel	Data type	Range	Multiplier /Divider	Factor	Offset	Unit
Ecumaster output ID (default: 0x400)								
0		Latitude	32-bit S	-90 – 90	1/10 ⁷	10 ⁻⁷	0	°
4		Logitude	32-bit S	-180 – 180	1/10 ⁷	10 ⁻⁷	0	°
Ecumaster output ID+1 (default: 0x401)								
0		Speed	16-bit S	-1179 – 1179	36/1000	0.036	0	km/h
2		Height	16-bit S	-32768– 32767	1/1	1	0	m
5		Satellites number	8-bit U	0 – 72	1/1	1	0	-
6	0 (0x0F)	GPS frame index	4-bit U	0 – 16	1/1	1	0	-
6	4 (0xF0)	Empty frame index	4-bit U	0 – 16	1/1	1	0	-
7	0 (0x07)	GPS status	3-bit U	1 – 5	1/1	1	0	-
Ecumaster output ID+2 (default: 0x402)								
0		Heading motion	16-bit U	0 – 360	1/1	1	0	°
2		Heading vehicle	16-bit U	0 – 360	1/1	1	0	°
4		X angle rate	16-bit S	-250 – 250	1/100	0.01	0	°/s
6		Y angle rate	16-bit S	-250 – 250	1/100	0.01	0	°/s
Ecumaster output ID+3 (default: 0x403)								
0		Z angle rate	16-bit S	-250 – 250	1/100	0.01	0	°/s
2		X acceleration	16-bit S	-4 – 4	1/100	0.01	0	g
4		Y acceleration	16-bit S	-4 – 4	1/100	0.01	0	g
6		Z acceleration	16-bit S	-4 – 4	1/100	0.01	0	g
Ecumaster output ID+4 (default: 0x404)								
0		UTC year	8-bit U	0 – 255	1/1	1	2000	-
1		UTC month	8-bit U	1 – 12	1/1	1	0	-

Byte	Bit	Channel	Data type	Range	Multiplier /Divider	Factor	Offset	Unit
2		UTC day	8-bit U	1 – 31	1/1	1	0	-
3		UTC hour	8-bit U	0 – 23	1/1	1	0	-
4		UTC minute	8-bit U	0 – 59	1/1	1	0	-
5		UTC second	8-bit U	0 – 60	1/1	1	0	-
6		UTC millisecond	16-bit U	0 – 65535	1000/65536	0.0153	0	-

Byte	Bit	Channel	Data type	Range	Multiplier /Divider	Factor	Offset	Unit
Ecumaster output ID+4 (default: 0x404)								
0		UTC year	8-bit U	0 – 255	1/1	1	2000	-
1		UTC month	8-bit U	1 – 12	1/1	1	0	-
2		UTC day	8-bit U	1 – 31	1/1	1	0	-
3		UTC hour	8-bit U	0 – 23	1/1	1	0	-
4		UTC minute	8-bit U	0 – 59	1/1	1	0	-
5		UTC second	8-bit U	0 – 60	1/1	1	0	-
6		UTC millisecond	16-bit U	0 – 65535	1000/65536	0.0153	0	-

Format M output:

Byte	Bit	Channel	Data type	Range	Multiplier /Divider	Factor	Offset	Unit
Format M output ID (default: 0x680)								
0		Latitude (M)	32-bit S	-90 – 90	1/10 ⁷	10 ⁻⁷	0	°
4		Longitude (M)	32-bit S	-180 – 180	1/10 ⁷	10 ⁻⁷	0	°
Format M output ID+1 (default: 0x681)								
0		Time (M)	32-bit S	0 – 235959999	1/1	1	0	-
4		Speed (M)	16-bit U	0 – 1800	1/10	0.1	0	km/h
6		Altitude (M)	16-bit S	-32768 – 32767	1/10	0.1	0	m
Format M output ID+2 (default: 0x682)								
0		Date (M)	24-bit U	0 – 311299	1/1	1	0	-

Byte	Bit	Channel	Data type	Range	Multiplier /Divider	Factor	Offset	Unit
3		Valid (M)	8-bit S	-1 – 1	1/1	1	0	-
4		True course (M)	16-bit S	-250 – 250	1/10	0.1	0	°
7		Satellites (M)	8-bit U	0 – 255	1/1	1	0	-
Format M output ID+3 (default: 0x683)								
4		FAA mode (M)	8-bit S	-1 – 1	1/1	1	0	-
5		Fix quality (M)	8-bit S	-1 – 1	1/1	1	0	-

High rate IMU output:

Byte	Bit	Channel	Data type	Range	Multiplier /Divider	Factor	Offset	Unit
High rate IMU output ID (default: 0x408)								
0		HR X ang rate	16-bit S	-250 – 250	1/100	0.01	0	°/s
2		HR Y ang rate	16-bit S	-250 – 250	1/100	0.01	0	°/s
4		HR Z ang rate	16-bit S	-250 – 250	1/100	0.01	0	°/s
High rate IMU output ID+1 (default: 0x409)								
0		HR X accel	16-bit S	-4 – 4	1/100	0.01	0	g
2		HR Y accel	16-bit S	-4 – 4	1/100	0.01	0	g
4		HR Z accel	16-bit S	-4 – 4	1/100	0.01	0	g

7. Document history

Version	Date	Changes
1.0	2023.04.03	Official release
2.0	2023.08.23	Updated for firmware 2.x Corrected the IMU update frequency to 200 Hz
3.0	2024.10.21	Document layout updated to follow the Ecumaster standard format The structure and text have been refined and improved for better readability and clarity
3.1	2025.04.04	The list of parameters and channels in the <i>Light Client</i> section has been organized into tables Minor update to the <i>CAN stream</i> table Added CAN termination information to the <i>Specification</i> table
3.2	2025.12.09	Added an important note to the <i>Installation</i> chapter