

Lambda Sensor LSU 4.9



- ▶ Application: lambda 0.65 to ∞
- ▶ Exhaust gas temperature: 930°C (1,030 for a short time)
- ▶ Hexagon temperature: 600°C
- ▶ Thread: M18x1.5
- ▶ Weight w/o wire: 75 g

This sensor is designed to measure the proportion of oxygen in exhaust gases of automotive engines (gasoline or Diesel).

The wide band lambda sensor LSU 4.9 is a planar ZrO_2 dual cell limiting current sensor with integrated heater. Its monotonic output signal in the range of lambda 0.65 to air makes the LSU 4.9 capable of being used as a universal sensor for lambda 1 measurement as well as for other lambda ranges. The connector module contains a trimming resistor, which defines the characteristic of the sensor.

The main benefit of the LSU 4.9 is the robust design combined with the high Bosch production quality standard.

This lambda sensor operates only in combination with a special LSU-IC, used in most Bosch Motorsport ECUs and lambda control units like LT4. You'll find this unit and more on our homepage at Electronics/Sensor Interfaces.

Application

Application	lambda 0.65 to ∞
Fuel compatibility	gasoline/Diesel/E85
Exhaust gas pressure	≤ 2.5 bar (higher with decrease accuracy)
Exhaust gas temperature range (operating)	$< 930^\circ\text{C}$
Exhaust gas temperature range (max.) for short time	$< 1,030^\circ\text{C}$
Hexagon temperature	$< 600^\circ\text{C}$
Wire and protective sleeve temperature	$< 250^\circ\text{C}$
Connector temperature	$< 140^\circ\text{C}$

Storage temperature range	-40 to 100°C
Max. vibration (stochastic peak level)	300 m/s ²

Technical Specifications

Variations

LSU 4.9 with automotive connector

Connector	1928.404.687 (Series production type, not available from Bosch Motorsport)
Mating connector	D261.205.356-01
Wire length L	95.0 cm

LSU 4.9 with motorsport connector

Connector	AS607-35PN
Mating connector	AS007-35SN
Wire length L	20.0 to 90.0 cm

Mechanical Data

Weight w/o wire	75 g
Thread	M18x1.5
Wrench size	22 mm
Tightening torque	40 to 60 Nm

Electrical Data

Power supply H+ nominal	7.5 V
System supply voltage	10.8 V to 16.5 V
Heater power steady state	7.5 W
Heater control frequency	≥ 100 Hz
Nominal resistance of Nernst cell	300 Ohm

Max current load for Nernst cell	250 μ A
----------------------------------	-------------

Characteristic

Signal output	I_p meas		
Accuracy at lambda 0.8	0.80 \pm 0.01		
Accuracy at lambda 1	1.016 \pm 0.007		
Accuracy at lambda 1.7	1.70 \pm 0.05		
I_p [mA]	lambda	U_A [V], v=17	U_A [V], v=8
-2.000	0.650	-	0.510
-1.602	0.700	-	0.707
-1.243	0.750	0.192	0.884
-0.927	0.800	0.525	1.041
-0.800	0.822	0.658	1.104
-0.652	0.850	0.814	1.177
-0.405	0.900	1.074	1.299
-0.183	0.950	1.307	1.409
-0.106	0.970	1.388	1.448
-0.040	0.990	1.458	1.480
0	1.003	1.500	1.500
0.015	1.010	1.515	1.507
0.097	1.050	1.602	1.548
0.193	1.100	1.703	1.596
0.250	1.132	1.763	1.624
0.329	1.179	1.846	1.663
0.671	1.429	2.206	1.832
0.938	1.701	2.487	1.964
1.150	1.990	2.710	2.069
1.385	2.434	2.958	2.186
1.700	3.413	3.289	2.342
2.000	5.391	3.605	2.490
2.150	7.506	3.762	2.565
2.250	10.119	3.868	2.614

Please note: U_A is not an output signal of the lambda sensor, but the output of the evaluation circuit. Only I_p correlates with the oxygen content of the exhaust gas. Amplification factor v=17 is typically used for lean applications (lambda>1), amplification factor v=8 is typically used for rich applications (lambda<1).

Heater Strategy

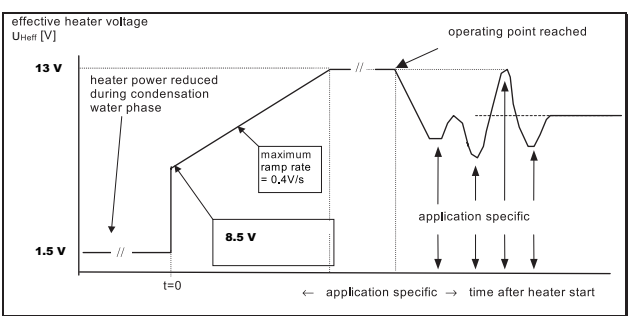

Connectors and Wires

Connector	Please see variations
Mating connector	Please see variations
Sleeve	fiber glass / silicone coated
Pin 1	Pump current APE / IP
Pin 2	Virtual ground IPN / VM
Pin 3	Heater voltage H- / Uh-
Pin 4	Heater voltage H+ / Uh+
Pin 5	Trim resistor RT / IA
Pin 6	Nernst voltage UN / RE
Wire length	Please see variations

Various motorsport and automotive connectors are available on request.

Installation Notes

- This lambda sensor operates only in combination with a special LSU-IC, used in most Bosch Motorsport ECUs and lambda control units like LT4. You'll find this unit and more on our homepage at Accessories/Expansion Modules.
- The lambda sensor should be installed at point which permits the measurement of a representative exhaust-gas mixture, which does not exceed the maximum permissible temperature.
- Install at a point where the gas is as hot as possible.
- Observe the maximum permissible temperature.
- As far as possible install the sensor vertically (wire upwards).
- The sensor is not to be fitted near to the exhaust pipe outlet, so that the influence of the outside air can be ruled out.
- The exhaust-gas passage opposite the sensor must be free of leaks in order to avoid the effects of leak-air.
- Protect the sensor against condensation water.
- The sensor is not to be painted, nor is wax to be applied or any other forms of treatment. Use only the recommended grease for lubricating the thread.
- Please find further application hints in the offer drawing at our homepage.

Safety Note

The sensor is not intended to be used for safety related applications without appropriate measures for signal validation in the application system.

Legal Restrictions

Generally blocked are direct and indirect business involving high risk destinations, including Russia, Belarus, Cuba, Iran, North Korea, Syria, Libya, Afghanistan, and certain non-governmental controlled Ukrainian regions. This list may change as geopolitics evolve.

Ordering Information

Lambda Sensor LSU 4.9

With automotive connector
Order number **0258.017.025**

Lambda Sensor LSU 4.9
With motorsport connector
Order number **B261.209.358-03**

Dimensions

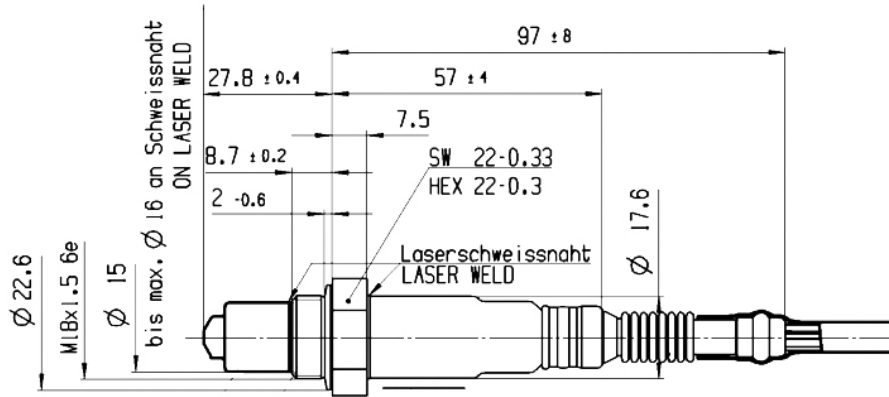

Mounting recommendation

Recommended design of the mating thread in the exhaust pipe:
T Hexagon > 600°C
or T Gas > 930°C

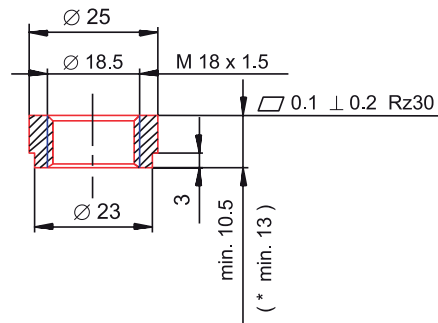
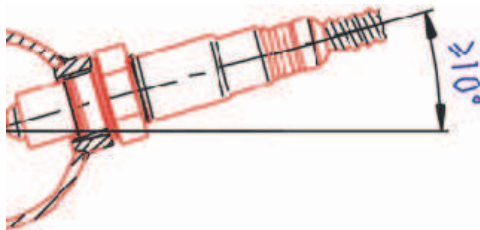

Represented by:

Europe:
Bosch Engineering GmbH
Motorsport
Robert-Bosch-Allee 1
74232 Abstatt
Germany
motorsport@bosch.com
www.bosch-motorsport.de

North America:
Bosch Engineering North America
Motorsport
38000 Hills Tech Drive
Farmington Hills, MI 48331-3417
United States of America
motorsport@bosch.com
www.bosch-motorsport.com

Asia-Pacific:
Bosch Engineering Japan K.K.
Motorsports Department
1-9-32 Nakagawachuo, Tsuzuki-ku
Yokohama-shi
Kanagawa, 224-8601
Japan
motorsport@jp.bosch.com
www.bosch-motorsport.jp

Australia, New Zealand and South Africa:
Robert Bosch Pty. Ltd
Motorsport
1555 Centre Road
Clayton, Victoria, 3168
Australia
motor.sport@au.bosch.com
www.bosch-motorsport.com.au